

**MANNESMANN
REXROTH****Fixed Displacement Pump A2FO**Series 6, for open circuits
Axial tapered piston - bent axis design**RE
91401/01.97**

Brueninghaus Hydromatik

Sizes 5...1000

Nom. Pressure up to 400 bar Peak Pressure up to 450 bar

replaces 11.95



The fixed displacement pump A2FO of axial piston, bent axis design is made suitable for hydrostatic drives in open circuits.

Output flow is proportional to drive speed and displacement. These pumps are suitable for use in mobile or industrial applications. The drive shaft bearings are designed to give the service life expected in these areas of operation.

Careful selection of the displacements offered, permit sizes to be matched to practically every application.

- Favourable power / weight ratio
- Compact and economic design
- Optimum efficiency
- One piece pistons with piston rings
- Patented cylinder block drive system

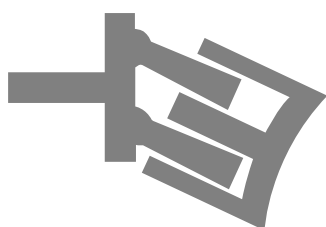

Fixed Displacement Pump A2FO

Ordering Code / Standard Program

(Ordering code size 5 see page 7)

A2F		O	/	6		-			
-----	--	---	---	---	--	---	--	--	--

Hydraulic fluid

Mineral oil (no code)	
HF-fluids	sizes 10...200 (no code)
	sizes 250...1000 ¹⁾
	E-

Axial piston unit

Bent axis design, fixed displacement	A2F
--------------------------------------	-----

Drive shaft bearings

	10...200	250..500	710..1000	
Mechanical bearings (no code)	●	●	—	
Long-Life bearings	—	●	●	L

Mode of operation

Pump, open circuit	O
--------------------	---

Size

≥ Displacement V _g (cm ³)																					
5	10	12	16	23	28	32	45	56	63	80	90	107	125	160	180	200	250	355	500	710	1000

Sizes 5...200: production plant Elchingen; Sizes 250...1000: production plant Horb

Series

	6
--	---

Index

	sizes 10...180	1
	size 200	3
	sizes 250...1000	0

Direction of rotation

Viewed on shaft end	clockwise	R
	anti-clockwise	L

Seals

	10...200	250...1000	
NBR (nitril-caoutchouc)	●	—	P
NBR (nitril-caoutchouc), shaft seal in FPM	●	—	N
FPM (fluor-caoutchouc)	●	●	V

Shaft end

	10	12	16	23	28	32	45	56	63	80	90	107	125	160	180	200	250	355	500	710	1000		
Splined shaft	●	●	●	●	●	●	●	●	●	●	●	●	●	●	●	●	—	—	—	—	—	—	A
DIN 5480	●	●	—	●	●	—	●	●	—	●	—	●	—	●	—	—	●	●	●	●	●	●	Z
Parallel shaft with	●	●	●	●	●	●	—	●	●	●	●	●	●	●	●	●	—	—	—	—	—	—	B
key, DIN 6885	●	●	—	●	●	—	●	●	—	●	—	●	—	●	—	—	●	●	●	●	●	●	P

Mounting flange

	10	12	16	23	28	32	45	56	63	80	90	107	125	160	180	200	250	355	500	710	1000		
ISO 4-hole	●	●	●	●	●	●	●	●	●	●	●	●	●	●	●	●	●	—	—	—	—	—	B
ISO 8-hole	—	—	—	—	—	—	—	—	—	—	—	—	—	—	—	—	—	●	●	●	●	●	H

Service line connections²⁾

A(B) SAE, at side	—	—	—	●	●	●	●	●	●	●	●	●	●	●	●	●	—	—	—	—	—	—	05
S SAE, at rear																							
A(B) threads at side	●	●	●	—	—	—	—	—	—	—	—	—	—	—	—	—	—	—	—	—	—	—	06
S threads, at rear																							
A(B)SAE, at rear	—	—	—	—	—	—	—	—	—	—	—	—	—	—	—	—	—	●	●	●	●	●	11
S SAE, at rear																							

 = preferred program (preferred types see page 15)

● = available
— = not available

¹⁾ only in connection with drive shaft bearings "L"
²⁾ threads of fixing screws are metric

Technical Data

Fluid

We request that before starting a project detailed information about the choice of pressure fluids and application conditions are taken from our catalogue sheets RE 90220 (mineral oil), RE 90221 (environmentally acceptable hydraulic fluids) and RE 90223 (fire resistance fluids, HF).

When using HF- or environmentally acceptable hydraulic fluids possible limitations for the technical data have to be taken into consideration. If necessary please consult our technical department (please indicate type of the hydraulic fluid used for your application on the order sheet).

Operating viscosity range

In order to obtain optimum efficiency and service life, we recommend that the operating viscosity (at operating temperature) be selected from within the range:

$$v_{\text{opt}} = \text{operating viscosity } 16 \dots 36 \text{ mm}^2/\text{s}$$

referred to the tank temperature (open circuit).

Viscosity limits

The limiting values for viscosity are as follows:

sizes 5...200

$v_{\text{min}} = 5 \text{ mm}^2/\text{s}$,
short term at a max. permissible temperature of $t_{\text{max}} = 115^\circ\text{C}$

$v_{\text{max}} = 1600 \text{ mm}^2/\text{s}$, short term on cold start ($t_{\text{min}} = -40^\circ\text{C}$)

sizes 250...1000

$v_{\text{min}} = 10 \text{ mm}^2/\text{s}$
short term at a max. permissible leakage oil temp. of $t_{\text{max}} = 90^\circ\text{C}$

$v_{\text{max}} = 1000 \text{ mm}^2/\text{s}$,
short term on cold start ($t_{\text{min}} = -25^\circ\text{C}$)

Please note that the max. fluid temperature is also not exceeded in certain areas (for instance bearing area).

At temperatures of -25°C up to -40°C special measures may be required for certain installation positions. Please contact us for further information.

Selection diagram

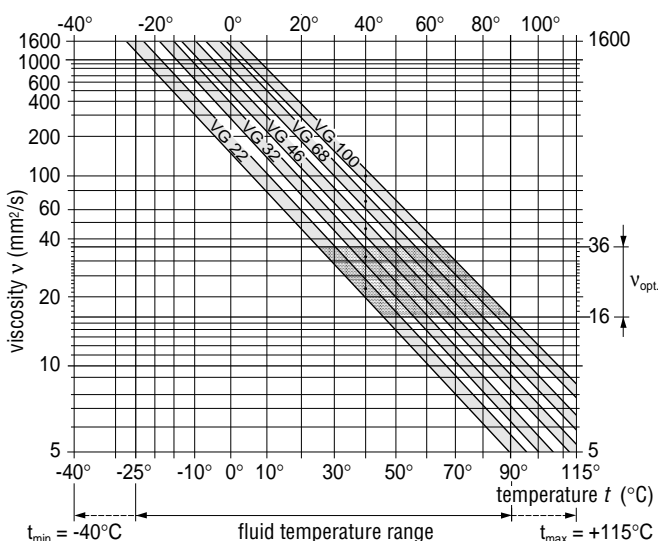

Notes on the selection of the hydraulic fluid

In order to select the correct fluid, it is necessary to know the operating temperature in the tank (open circuit) in relation to the ambient temperature.

The hydraulic fluid should be selected so that within the operating temperature range, the operating viscosity lies within the optimum range (v_{opt}) (see shaded section of the selection diagram). We recommend that the highest possible viscosity range should be chosen in each case.

Example: At an ambient temperature of $X^\circ\text{C}$ the operating temperature is 60°C . Within the operating viscosity range (v_{opt} ; shaded area), this corresponds to viscosity ranges VG 46 or VG 68. VG 68 should be selected.

Important: The leakage oil (case drain oil) temperature is influenced by pressure and pump speed and is always higher than the tank temperature. However, at no point in the circuit may the temperature exceed 115°C for sizes 5...200 or 90°C for sizes 250...1000.

If it is not possible to comply with the above conditions because of extreme operating parameters or high ambient temperatures please consult us.

Filtration

The finer the filtration the better the achieved purity grade of the pressure fluid and the longer the life of the axial piston unit.

To ensure the functioning of the axial piston unit a minimum purity grade of:

9 to NAS 1638

6 to SAE

18/15 to ISO/DIS 4406 is necessary.

At very high temperatures of the hydraulic fluid (90°C to max. 115°C , not permissible for sizes 250...1000!) at least cleanliness class

8 to NAS 1638

5 to SAE

17/14 to ISO/DIS 4406 is necessary.

If above mentioned grades cannot be maintained please consult supplier.

Direction of Flow

clockwise rotation

anti-clockwise rotation

S to B

S to A

Installation position

Any installation position possible. The pump housing must be filled with fluid prior the commissioning, and must remain full whenever it is operating.

For extensive information on installation position, please consult our data sheet RE 90270 before completing your design work.

Symbol

Connections

A, B service line port

S suction port

T drain port

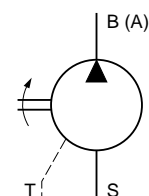

Fixed Displacement Pump A2FO

Technical Data

Case drain pressure

The lower the speed and the case drain pressure the higher the life expectation of the shaft seal ring.

Shaft seal ring FPM (fluor-caoutchouc)

The values shown in the diagram are permissible loads of the seal ring and shall not be exceeded.

At stationary pressure loads in the range of the max. admissible leakage pressure a reduction of the life experience of the seal ring will result.

For a short period ($t < 5$ min.) for the sizes 5...200 pressure loads up to 5 bar independent from rotational speeds are permissible.

Sizes 10...200

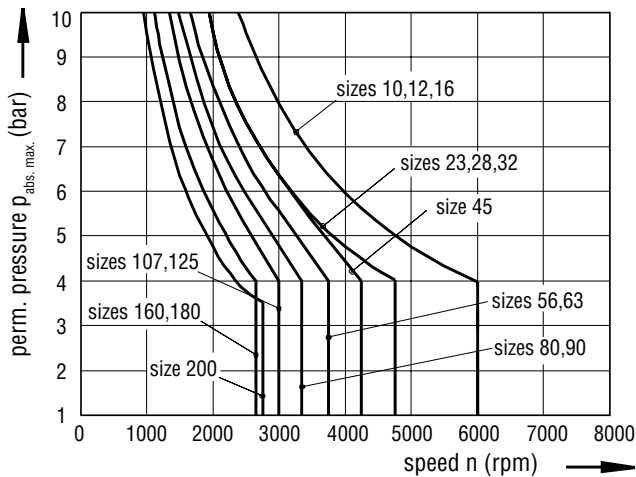

Sizes 250...1000

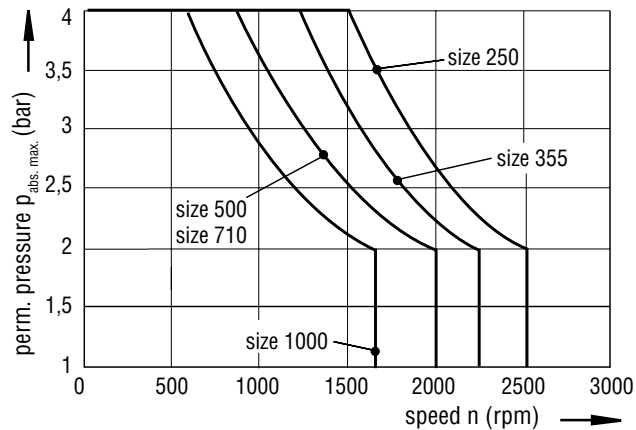

Shaft seal ring NBR (nitril-caoutchouc)

For seal rings of NBR 33% reduced values for the max. permissible housing pressure $p_{abs.max}$ are to be considered compared with seals of FPM.

Special operation conditions may require limitations of these values.

Note:

- maximum permissible pump speeds are given in the table on page 5
- max. perm. casing pressure $p_{abs.max}$ $\underline{\hspace{1cm}}$ 10 bar (sizes 5...200)
 $\underline{\hspace{1cm}}$ 4 bar (sizes 250...1000)
- the pressure in the housing must be the same as or greater than the external pressure on the shaft seal.

Working pressure range inlet

Minimum pressure at port S

$p_{abs.min}$ $\underline{\hspace{1cm}}$ 0,8 bar

Working pressure range outlet

Maximum pressure at port A or B

(Pressure data to DIN 24312)

Size 5	Shaft end B	Shaft end C
Nominal pressure p_N	210 bar	315 bar
Peak pressure p_{max}	250 bar	350 bar

Sizes 10...200	Shaft end A	Shaft end Z, B, P
Nominal pressure p_N	400 bar	350 bar *)
Peak pressure p_{max}	450 bar	400 bar

*) Attention: shaft end Z and P with drives of radial force loads at the drive shaft (pinion V-belt drives) necessitate reduction of the nominal pressure to $p_N = 315$ bar (please contact us).

Sizes 250...1000

Nominal pressure p_N	350 bar
Peak pressure p_{max}	400 bar

With pulsating loads above 315 bar we recommend using the model with splined shaft, standard version A (sizes 10...200) or with splined shaft Z (sizes 250...1000).

Long-Life bearings (L) (sizes 250...1000)

(for high life expectancy and use of HF-fluids)

The outer dimensions of the axial piston pumps are identical to standard design (without long life bearings). The change from standard design to long life bearing system is possible.

We recommend to apply bearing flushing at port U.

Bearing flushing

For sizes 250...1000 bearing and housing flushing is possible through port U.

Flushing flow (recommendation)

Size	250	355	500	710	1000
q_{flush} (L/min)	10	16	20	25	25

Fixed Displacement Pump A2FO

Technical Data

Table of values

(theoretical values, without considering η_{mh} and η_v ; values rounded)

Size			5	10	12	16	23	28	32	45	56	63	80
Displacement	V_g	cm ³	4,93	10,3	12,0	16,0	22,9	28,1	32	45,6	56,1	63	80,4
Max. speed ¹⁾	n_{max}	rpm	5600	3150	3150	3150	2500	2500	2500	2240	2000	2000	1800
Max. perm. speed with increased input pressure p_{abs}	$n_{max perm.}$	rpm	8000	6000	6000	6000	4750	4750	4750	4250	3750	3750	3350
Max. perm. output flow, at $n_{max}^{2)}$	$q_{V max}$	L/min	27	32	37	49	56	69	78	100	110	123	141
Max. power at $q_{V max}$	$\Delta p = 350$ bar	P_{max}	9,6 ³⁾	19	22	30	33	41	46	59	65	74	84
	$\Delta p = 400$ bar	P_{max}	–	22	25	34	38	47	53	68	75	84	96
Torque constants	T_K	Nm/bar	0,076	0,164	0,19	0,25	0,36	0,445	0,509	0,725	0,89	1,0	1,27
Perm. torque	$\Delta p = 350$ bar	T	24,7 ³⁾	57	67	88	126	156	178	254	312	350	445
	$\Delta p = 400$ bar	T	–	65	76	100	144	178	204	290	356	400	508
Case volume		L		0,17	0,17	0,17	0,20	0,20	0,20	0,33	0,45	0,45	0,55
Moment of inertia about drive axis	J	kgm ²	0,00008	0,0004	0,0004	0,0004	0,0012	0,0012	0,0012	0,0024	0,0042	0,0042	0,0072
Weight (approx.)	m	kg	2,5	5,4	5,4	5,4	9,5	9,5	9,5	13,5	18	18	23
Size			90	107	125	160	180	200	250	355	500	710	1000
Displacement	V_g	cm ³	90	106,7	125	160,4	180	200	250	355	500	710	1000
Max. speed ¹⁾	n_{max}	rpm	1800	1600	1600	1450	1450	1550	1500	1320	1200	1200	950
Max. perm. speed with increased input pressure p_{abs}	$n_{max perm.}$	rpm	3350	3000	3000	2650	2650	2750	2500	2240	1500	1500	1200
Max. perm. output flow, at $n_{max}^{2)}$	$q_{V max}$	L/min	158	167	196	228	255	304	364	455	582	826	921
Max. power at $q_{V max}$	$\Delta p = 350$ bar	P_{max}	95	100	116	136	152	177	212	265	340	482	537
	$\Delta p = 400$ bar	P_{max}	108	114	133	155	174	203	–	–	–	–	–
Torque constants	T_K	Nm/bar	1,43	1,70	1,99	2,54	2,86	3,18	3,98	5,64	7,95	11,3	15,9
Perm. torque	$\Delta p = 350$ bar	T	501	595	697	889	1001	1114	1391	1979	2785	3955	5570
	$\Delta p = 400$ bar	T	572	680	796	1016	1144	1272	–	–	–	–	–
Case volume		L	0,55	0,8	0,8	1,1	1,1		2,5	3,5			7,8
Moment of inertia about drive axis	J	kgm ²	0,0072	0,0116	0,0116	0,0220	0,0220	0,0378	0,061	0,102	0,178	0,55	0,55
Weight (approx.)	m	kg	23	32	32	45	45	66	73	110	155	322	336

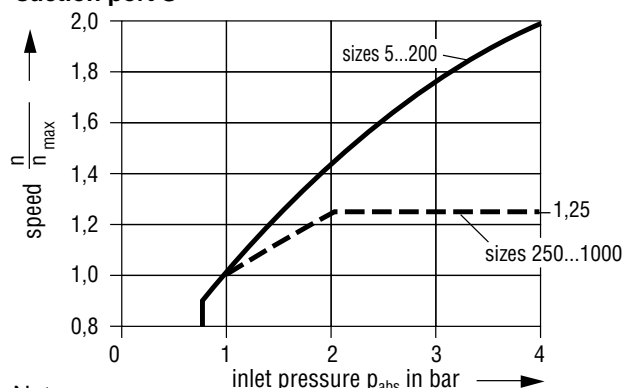
¹⁾ The values shown are valid for an absolute pressure (p_{abs}) of 1 bar at the suction inlet S and when operated on mineral oil.By increase of the input pressure ($p_{abs} > 1$ bar) the rotational speeds can be increased to the max. admissible speeds (speed limits) (see diagram).²⁾ 3 % volumetric loss included ³⁾ $\Delta p = 315$ barMax perm. speed with increased inlet pressure p_{abs} at suction port S

Note:

- max. perm. speed $n_{max perm.}$ (speed limit)
- min. perm. pressure at port S
- admissible values for the drive shaft seal

Calculation of size

$$\text{Flow} \quad q_v = \frac{V_g \cdot n \cdot \eta_v}{1000} \quad \text{in L/min}$$

$$\text{Torque} \quad T = \frac{V_g \cdot \Delta p}{20 \pi \cdot \eta_{mh}} = \frac{1,59 \cdot V_g \cdot \Delta p}{100 \cdot \eta_{mh}} \quad \text{in Nm}$$

$$\text{Power} \quad P = \frac{2 \pi \cdot T \cdot n}{60 \cdot 1000} = \frac{T \cdot n}{9549} = \frac{q_v \cdot \Delta p}{600 \cdot \eta_t} \quad \text{in kW}$$

 V_g = geometric displacement per rev. in cm³ T = torque in Nm Δp = pressure differential in bar n = speed in rpm η_v = volumetric efficiency η_{mh} = mech. -hyd. efficiency η_t = overall efficiency

Fixed Displacement Pump A2FO

Technical Data

Output drive

Permissible axial and radial loads on drive shaft

The values given are maximum values and do not apply to continuous operation

Size		5	10	12	16	23	28	32	45	56	63	80
a	mm	12	16	16	16	16	16	16	18	18	18	20
$F_{q \max}$	N	710	2350	2750	3700	4300	5400	6100	8150	9200	10300	11500
$\pm F_{ax \max}$	N	180	320	320	320	500	500	500	630	800	800	1000
$\pm F_{ax \text{ perm.}}/\text{bar}$	N/bar	1,5	3,0	3,0	3,0	5,2	5,2	5,2	7,0	8,7	8,7	10,6

Size		90	107	125	160	180	200	250	355	500	710	1000	
a	mm	20	20	20	25	25	25	41	52,5	52,5	67,5	67,5	
$F_{q \max}$	N	12900	13600	15900	18400	20600	22900	1200 ¹⁾	1500 ¹⁾	1900 ¹⁾	3000 ¹⁾	2600 ¹⁾	
$\pm F_{ax \max}$	N	$+F_{ax \max}$	1000	1250	1250	1600	1600	1600	4000	5000	6250	10000	10000
		$-F_{ax \max}$	1000	1250	1250	1600	1600	1600	1200	1500	1900	3000	2600
$\pm F_{ax \text{ perm.}}/\text{bar}$	N/bar	10,6	12,9	12,9	16,7	16,7	16,7	²⁾	²⁾	²⁾	²⁾	²⁾	

¹⁾ Axial piston unit in stationary or in bypass operation, please contact us when appearing higher forces!

²⁾ Please contact us!

Code explanation

- a = distance of F_q from shaft shoulder
- $F_{q \max}$ = max. perm. radial force at distance a (at intermittent operation)
- $\pm F_{ax \max}$ = max. perm. axial force when stationary or when axial piston unit is running at zero pressure
- $\pm F_{ax \text{ perm.}}/\text{bar}$ = perm. axial force/bar working pressure

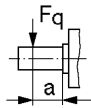

The direction of the max. perm. axial force must be noted by sizes 5...200

- $-F_{ax}$ = increases bearing life
- $+F_{ax}$ = reduces bearing life (avoid if possible)

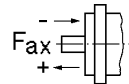

Optimal force direction of F_q (valid for sizes 10...180)

By means of appropriate force directions of F_q the bearing load caused by inside rotary group forces can be reduced. An optimal life expectation of the bearing can be reached.

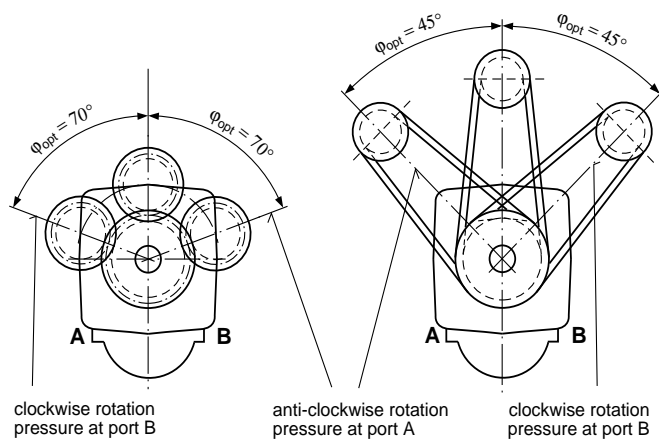

Unit Dimensions, Size 5

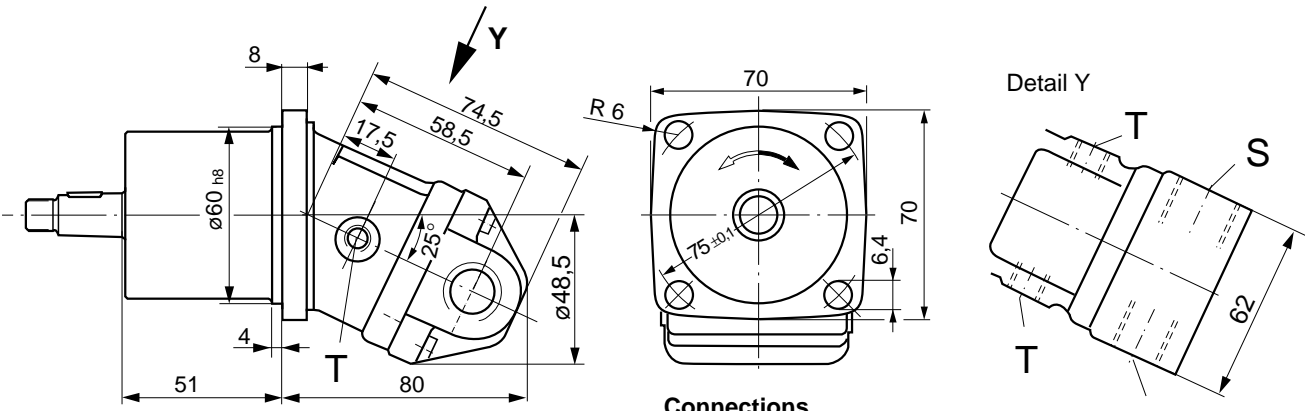

- Connections**
- B, (A) service line ports M 18x1,5
 - S suction port M 22x1,5
 - T drain port M 10x1, both sides

Shaft ends

B Parallel shaft with key A4x4x20
DIN 6885

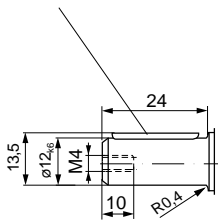

Nominal pressure
 $p_N = 210$ bar

C Tapered shaft with spigot and spring washer 3x5
DIN 6888

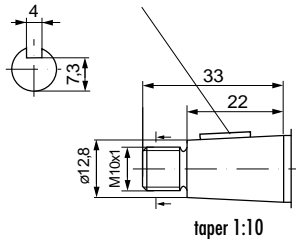

Nominal pressure
 $p_N = 315$ bar

Ordering Code / Standard Program

Size 5

A2F 5 6.0 7

Additional instructions in text form

Axial piston unit

Bent axis design, fixed displacement **A2F**

Size

Displacement V_g (cm³) **5**

Direction of rotation

Viewed on shaft end
 clockwise **R**
 anti-clockwise **L**

Series

6.0

Shaft end

Parallel shaft with key DIN 6885 **B**
 Tapered shaft with spigot and spring washer DIN 6888 **C**

Service line connections

Threads at side, metric **7**

Seals

The fixed pump A2F 5 is equipped with NBR (Nitril-caoutchouc) seals in standard design. In case of need FPM- (fluor-caoutchouc) seals please indicate when ordering in clear text:
 "with FPM-seals"

█ = preferred program
 (preferred types see page 15)

Unit Dimensions, Sizes 10, 12, 16

Note:

For anti-clockwise rotation port plate is rotated through 180°!

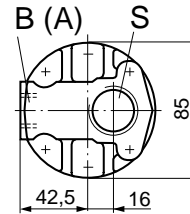
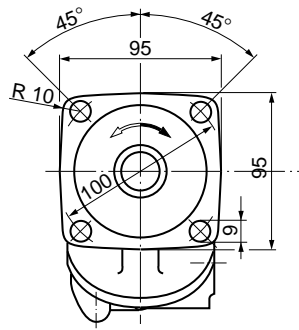
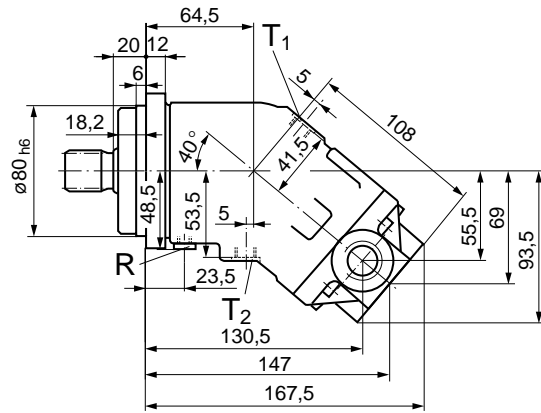

Connections

- B(A) service line ports M22x1,5
- S suction port M33x2
- T₁, T₂ drain port (1 port plugged) M 12x1,5
- R air bleed (plugged) M8x1

Shaft ends

Sizes 10, 12, 16

A Splined shaft, DIN 5480
W 25x1,25x30x18x9g

Sizes 10, 12

Z Splined shaft, DIN 5480
W 20x1,25x30x14x9g

Sizes 10, 12, 16

B Parallel shaft with key,
AS 8x7x32, DIN 6885

Sizes 10, 12

P Parallel shaft with key,
AS 6x6x32, DIN 6885

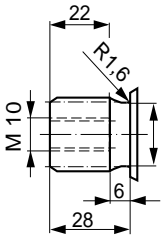

p_N = 400 bar

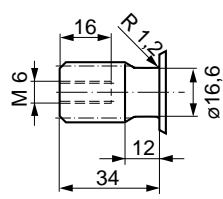

p_N = 350 bar

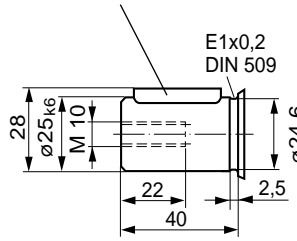

p_N = 350 bar

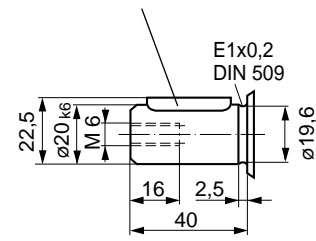

p_N = 350 bar

Unit Dimensions, Sizes 23, 28, 32

Note:

For anti-clockwise rotation port plate is rotated through 180°!

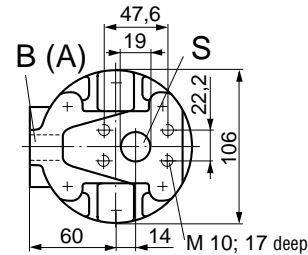
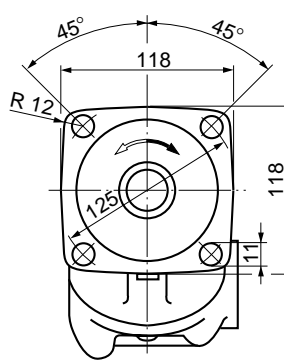
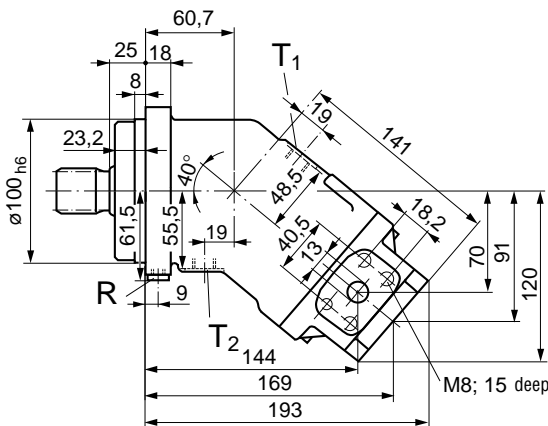

Connections

- B(A) service line ports SAE 1/2"
420 bar (6000 psi) high pressure series
- S suction port SAE 3/4"
350 bar (5000 psi) standard series
- T₁, T₂ drain port (1 port plugged) M 16x1,5
- R air bleed (plugged) M 10x1

Shaft ends

Sizes 23, 28, 32

A Splined shaft, DIN 5480
W 30x2x30x14x9g

Sizes 23, 28

Z Splined shaft, DIN 5480
W 25x1,25x30x18x9g

Sizes 23, 28, 32

B Parallel shaft with key
AS 8x7x40, DIN 6885

Sizes 23, 28

P Parallel shaft with key
AS 8x7x40, DIN 6885

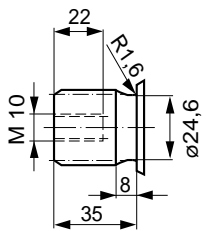

p_N = 400 bar

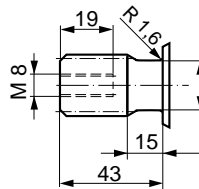

p_N = 350 bar

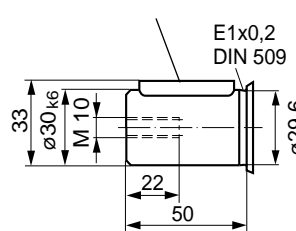

p_N = 350 bar

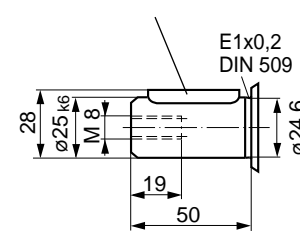

p_N = 350 bar

Unit Dimensions, Size 45

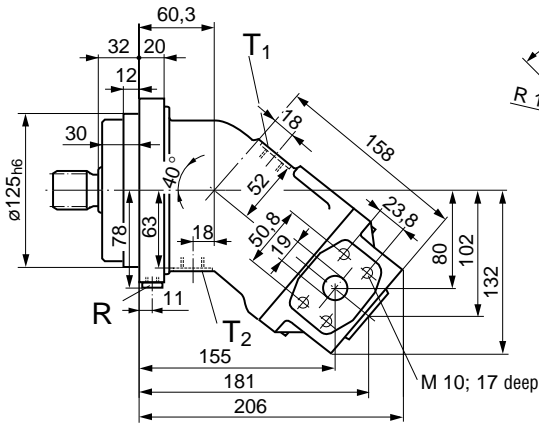

Note:
For *anti-clockwise* rotation port plate is rotated through 180°!

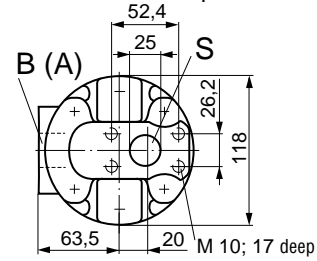

Connections

- B(A) service line ports SAE 3/4"
420 bar (6000 psi) high pressure series
- S suction port SAE 1"
350 bar (5000 psi) standard series
- T₁, T₂ drain port (1 port plugged) M 18x1,5
- R air bleed (plugged) M 12x1,5

Shaft ends

A Splined shaft, DIN 5480
W 32x2x30x14x9g

Z Splined shaft, DIN 5480
W 30x2x30x14x9g

P Parallel shaft with key
AS 8x7x50, DIN 6885

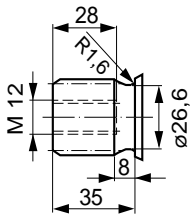

p_N = 400 bar

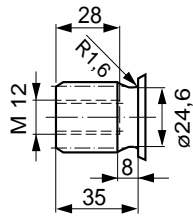

p_N = 350 bar

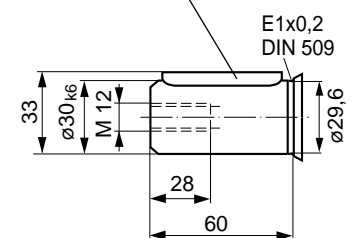

p_N = 350 bar

Unit Dimensions, Sizes 56, 63

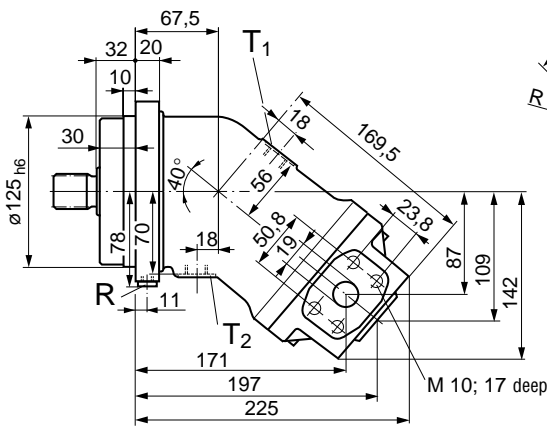

Note:
For *anti-clockwise* rotation port plate is rotated through 180°!

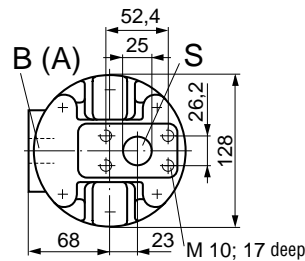

Connections

- B(A) service line ports SAE 3/4"
420 bar (6000 psi) high pressure series
- S suction port SAE 1"
350 bar (5000 psi) standard series
- T₁, T₂ drain port (1 port plugged) M 18x1,5
- R air bleed (plugged) M 12x1,5

Shaft ends

Sizes 56, 63

A Splined shaft, DIN 5480
W 35x2x30x16x9g

Size 56

Z Splined shaft, DIN 5480
W 30x2x30x14x9g

Sizes 56, 63

B Parallel shaft with key
AS 10x8x50, DIN 6885

Size 56

P Parallel shaft with key
AS 8x7x50, DIN 6885

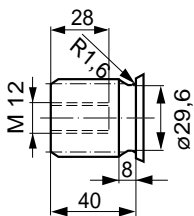

p_N = 400 bar

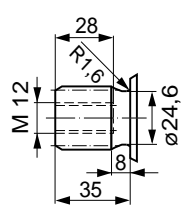

p_N = 350 bar

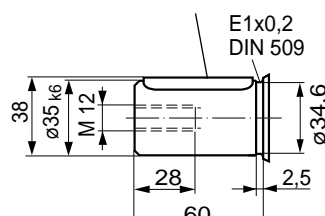

p_N = 350 bar

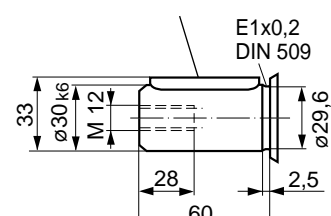

p_N = 350 bar

Unit Dimensions, Sizes 80, 90

Note:

For anti-clockwise rotation port plate is rotated through 180°!

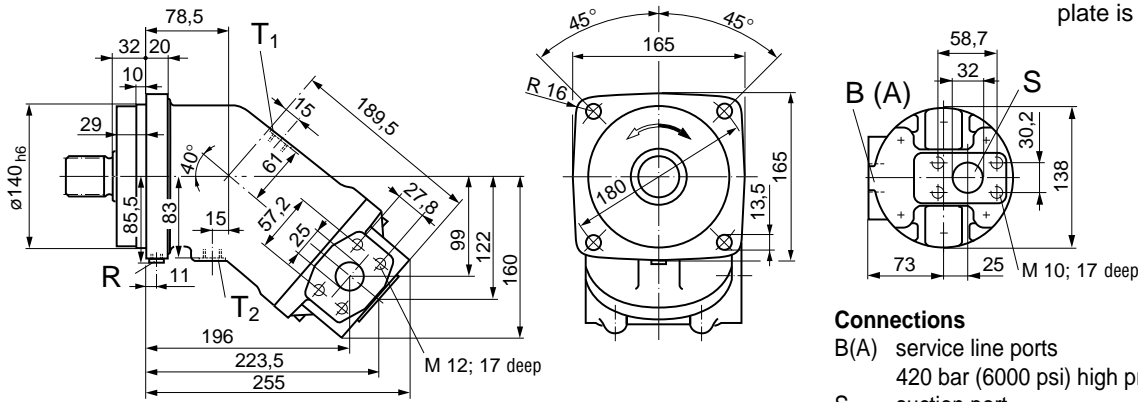

Connections

- B(A) service line ports SAE 1" 420 bar (6000 psi) high pressure series
- S suction port SAE 1 1/4" 350 bar (5000 psi) standard series
- T₁, T₂ drain port (1 port plugged) M 18x1,5
- R air bleed (plugged) M 12x1,5

Shaft ends

Sizes 80, 90

A Splined shaft, DIN 5480 W 40x2x30x18x9g

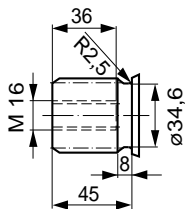

p_N = 400 bar

Size 80

Z Splined shaft, DIN 5480 W 35x2x30x16x9g

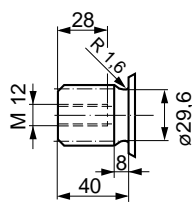

p_N = 350 bar

Sizes 80, 90

B Parallel shaft with key AS 12x8x56, DIN 6885

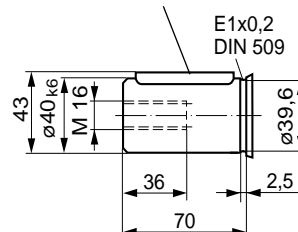

p_N = 350 bar

Size 80

P Parallel shaft with key AS 10x8x56, DIN 6885

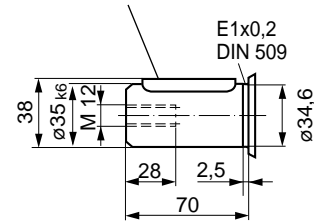

p_N = 350 bar

Unit Dimensions, Sizes 107, 125

Dimensions brackets for size 107

Note:

For anti-clockwise rotation port plate is rotated through 180°!

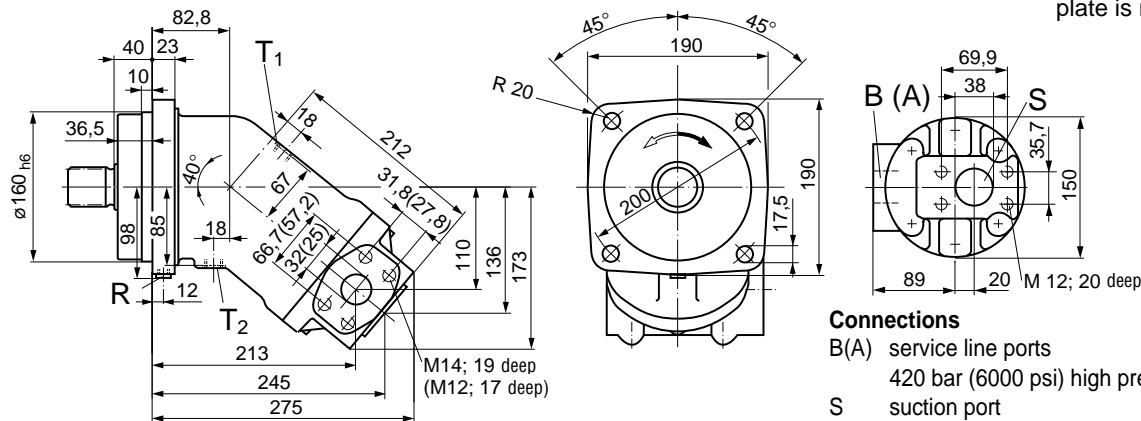

Connections

- B(A) service line ports SAE 1 1/4" (1") 420 bar (6000 psi) high pressure series
- S suction port SAE 1 1/2" 210 bar (3000 psi) standard series
- T₁, T₂ drain port (1 port plugged) M 18x1,5
- R air bleed (plugged) M 14x1,5

Shaft ends

Sizes 107, 125

A Splined shaft, DIN 5480 W 45x2x30x21x9g

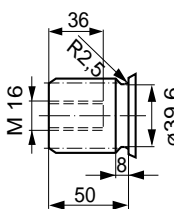

p_N = 400 bar

Size 107

Z Splined shaft, DIN 5480 W 40x2x30x18x9g

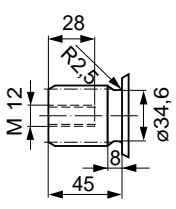

p_N = 350 bar

Sizes 107, 125

B Parallel shaft with key AS 14x9x63, DIN 6885

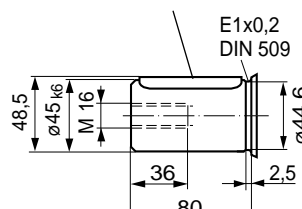

p_N = 350 bar

Size 107

P Parallel shaft with key AS 12x8x63, DIN 6885

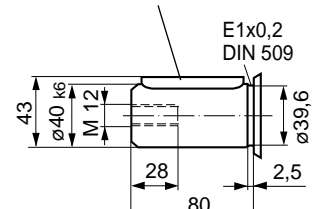

p_N = 350 bar

Unit Dimensions, Sizes 160, 180

Note:

For *anti-clockwise* rotation port plate is rotated through 180°!

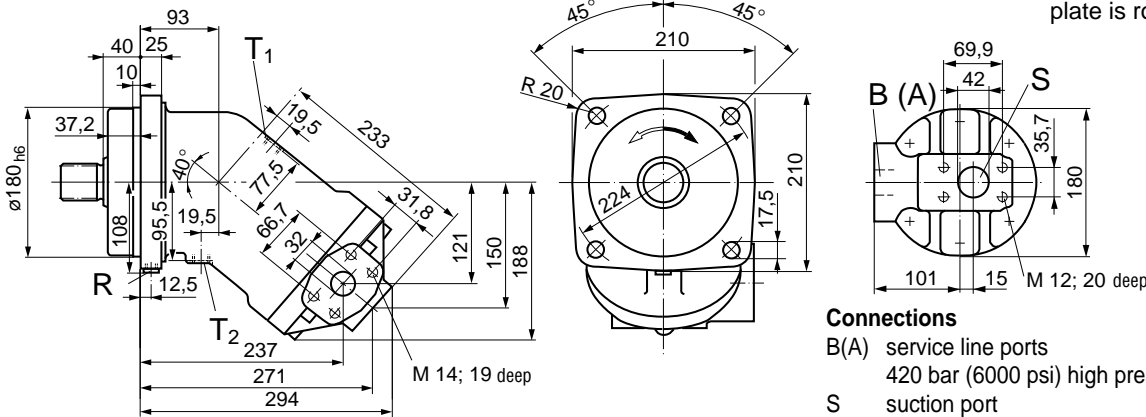

Connections

- B(A) service line ports SAE 1 1/4"
420 bar (6000 psi) high pressure series
- S suction port SAE 1 1/2"
210 bar (3000 psi) standard series
- T₁, T₂ drain port (1 port plugged) M 22x1,5
- R air bleed (plugged) M 14x1,5

Shaft ends

Sizes 160, 180

A Splined shaft, DIN 5480
W 50x2x30x24x9g

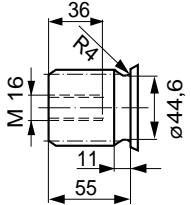

p_N = 400 bar

Size 160

Z Splined shaft, DIN 5480
W 45x2x30x21x9g

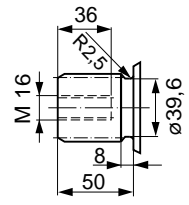

p_N = 350 bar

Sizes 160, 180

B Parallel shaft with key
AS 14x9x70, DIN 6885

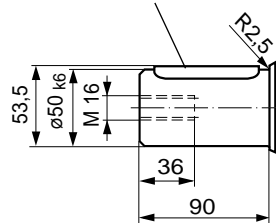

p_N = 350 bar

Size 160

P Parallel shaft with key
AS 14x9x70, DIN 6885

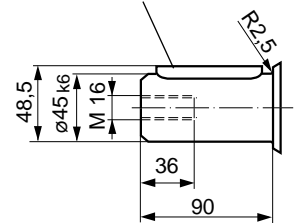

p_N = 350 bar

Unit Dimensions, Size 200

Note:

For *anti-clockwise* rotation port plate is rotated through 180°!

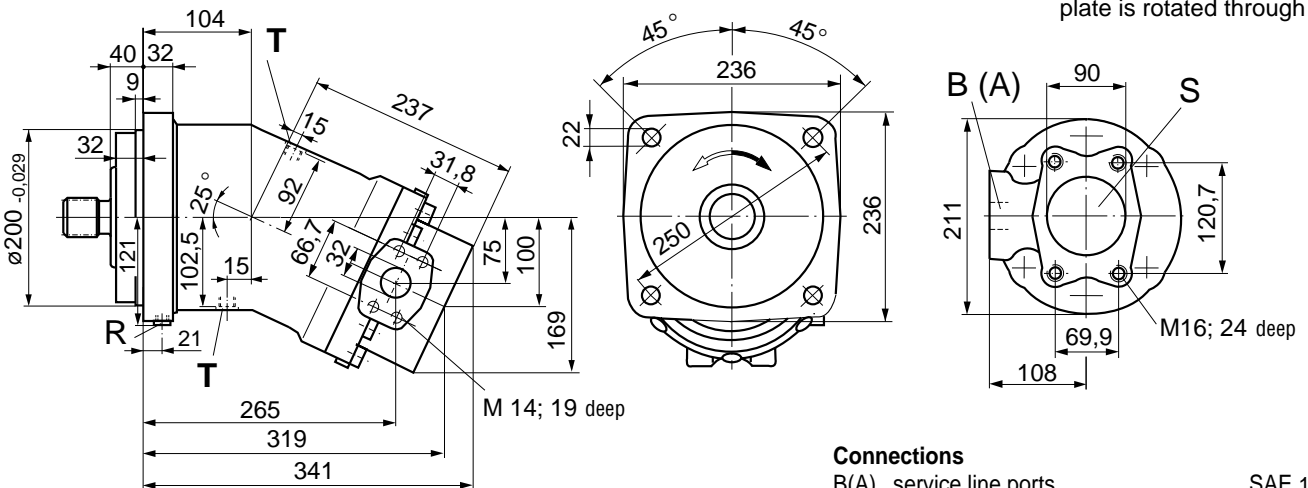

Connections

- B(A) service line ports SAE 1 1/4"
420 bar (6000 psi) high pressure series
- S suction port SAE 3 1/2"
35 bar (500 psi) standard series
- T drain port (1 port plugged) M 22x1,5
- R air bleed (plugged) M 14x1,5

Shaft ends

A Splined shaft, DIN 5480
W 50x2x30x24x9g

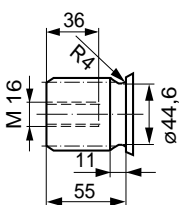

p_N = 400 bar

B Parallel shaft with key
AS 14x9x70, DIN 6885

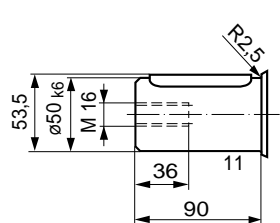

p_N = 350 bar

Unit Dimensions, Size 250

Note:

For anti-clockwise rotation port plate is rotated through 180°!

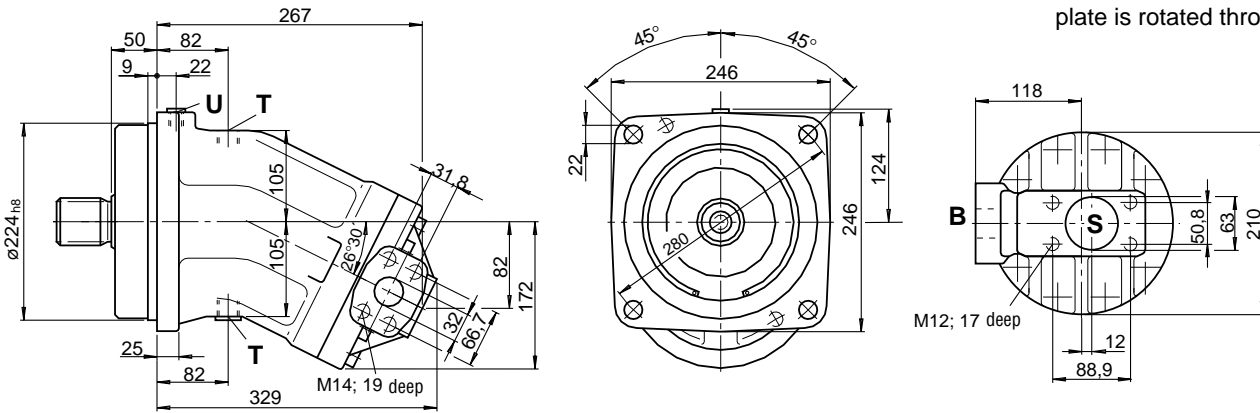

Shaft ends

Z Splined shaft, DIN 5480
W 50x2x30x24x9g

P Parallel shaft with key
AS 14x9x80, DIN 6885

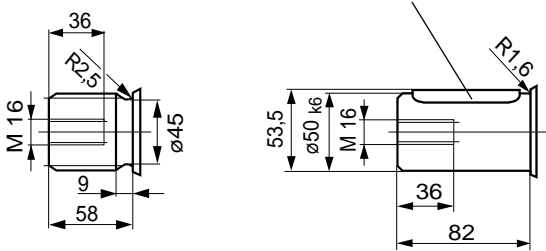

$p_N = 350$ bar

$p_N = 350$ bar

Connections

- B(A) service line ports SAE 1 1/4"
- 420 bar (6000 psi) high pressure series
- S suction port SAE 2 1/2"
- 210 bar (3000 psi) standard series
- T drain port (1 port plugged) M 22x1,5
- U port for bearing flushing (plugged) M 14x1,5

Unit Dimensions, Size 355

Note:

For anti-clockwise rotation port plate is rotated through 180°!

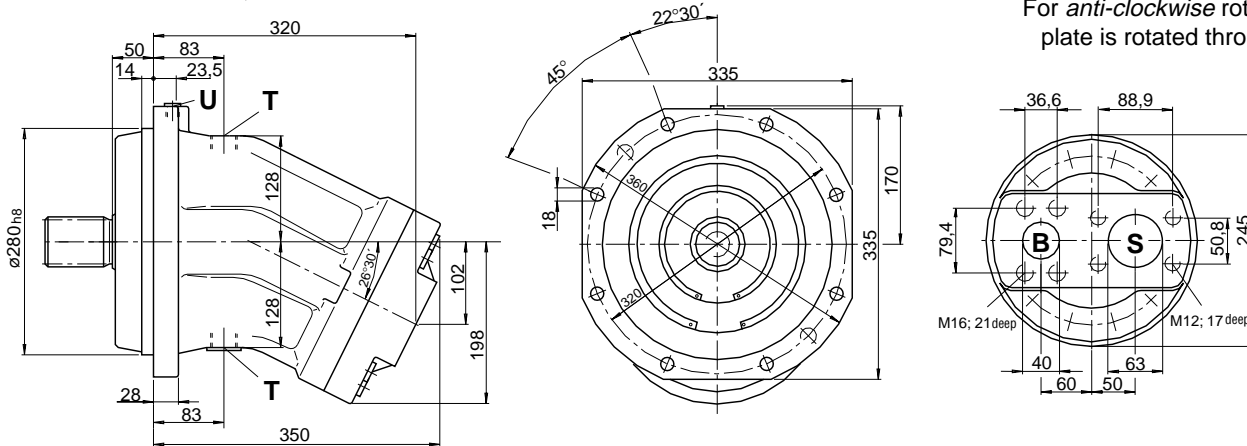

Shaft ends

Z Splined shaft, DIN 5480
W 60x2x30x28x9g

P Parallel shaft with key
AS 18x11x100, DIN 6885

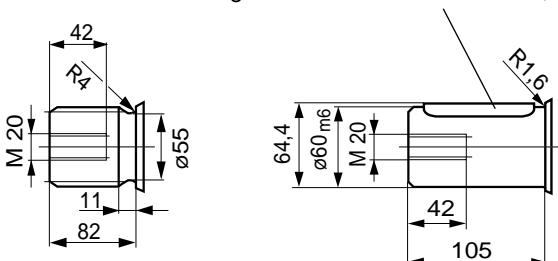

$p_N = 350$ bar

$p_N = 350$ bar

Connections

- B(A) service line ports SAE 1 1/2"
- 420 bar (6000 psi) high pressure series
- S suction port SAE 2 1/2"
- 210 bar (3000 psi) standard series
- T drain port (1 port plugged) M 33x2
- U port for bearing flushing (plugged) M 14x1,5

Unit Dimensions, Size 500

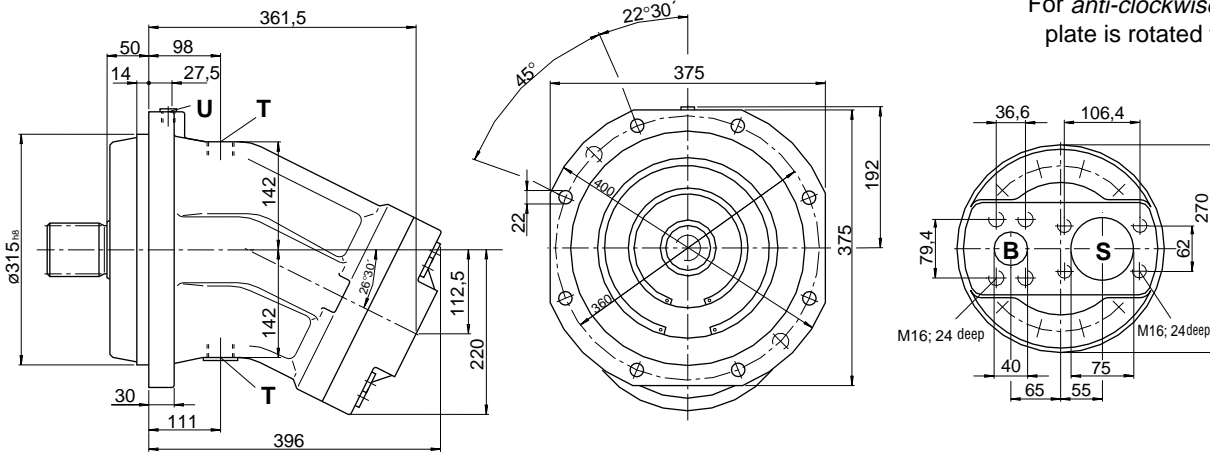

Note:
For anti-clockwise rotation port plate is rotated through 180°!

Shaft ends

Z Splined shaft, DIN 5480
W 70x3x30x22x9g

P Parallel shaft with key
AS 20x12x100, DIN 6885

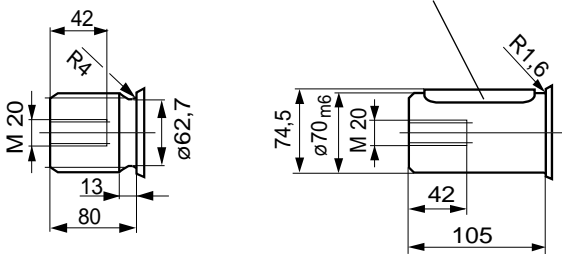

$p_N = 350$ bar

$p_N = 350$ bar

Connections

B(A)	service line ports	SAE 1 1/2"
	420 bar (6000 psi) high pressure series	
S	suction port	SAE 3"
	(2000 psi) standard series	
T	drain port (1 port plugged)	M 33x2
U	port for bearing flushing (plugged)	M 18x1,5

Unit Dimensions, Size 710

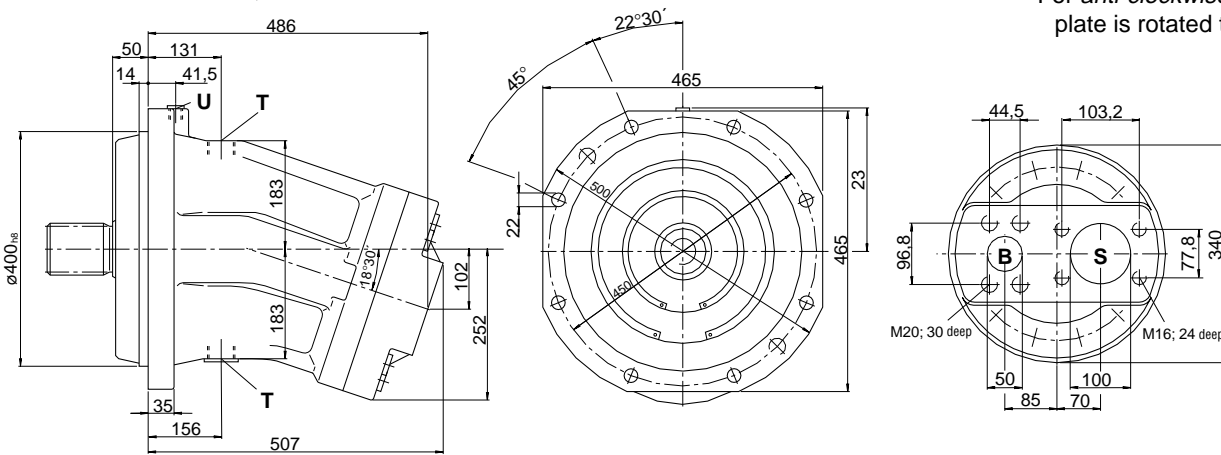

Note:
For anti-clockwise rotation port plate is rotated through 180°!

Shaft ends

Z Splined shaft, DIN 5480
W 90x3x30x28x9g

P Parallel shaft with key
AS 25x14x125, DIN 6885

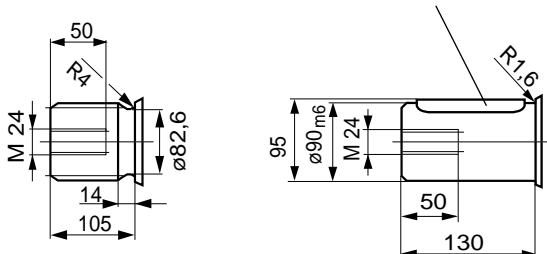

$p_N = 350$ bar

$p_N = 350$ bar

Connections

B(A)	service line ports	SAE 2"
	420 bar (6000 psi) high pressure series	
S	suction port	SAE 4"
	35 bar (500 psi) standard series	
T	drain port (1 port plugged)	M 42x2
U	port for bearing flushing (plugged)	M 18x1,5

Unit Dimensions, Size 1000

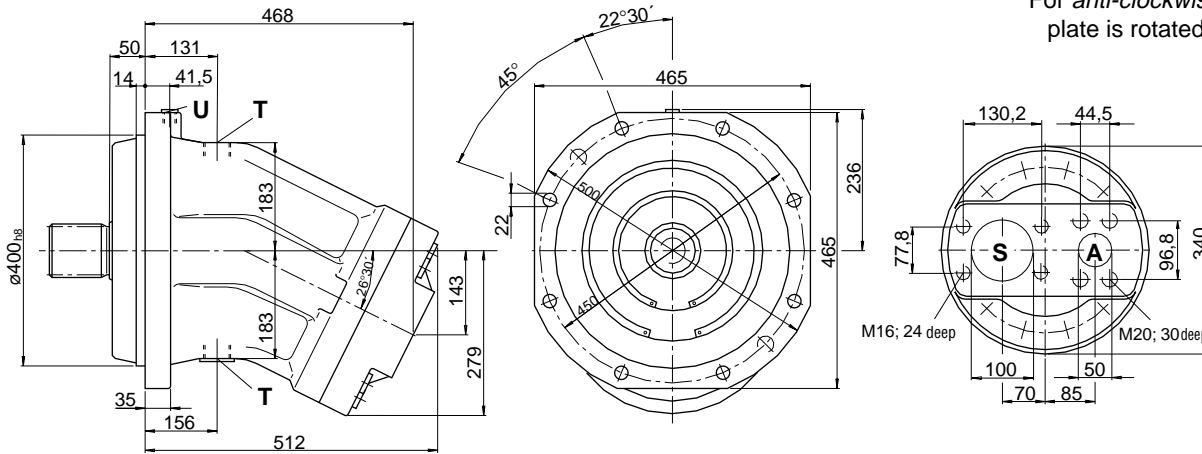

Note:

For anti-clockwise rotation port plate is rotated through 180°!

Shaft ends

Z Splined shaft, DIN 5480
W 90x3x30x28x9g

P Parallel shaft with key
AS 25x14x125, DIN 6885

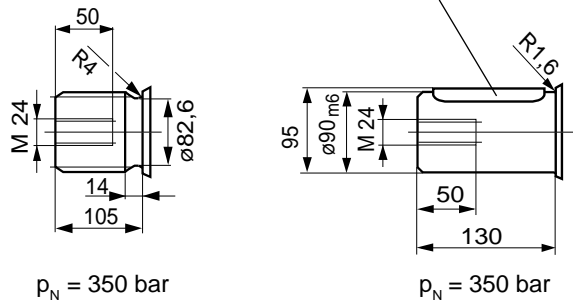

Connections

- B(A) service line ports SAE 2"
420 bar (6000 psi) high pressure series
- S suction port SAE 4"
35 bar (500 psi) standard series
- T drain port (1 port plugged) M 42x2
- U port for bearing flushing (plugged) M 18x1,5

Fixed Displacement Pump A2FO

Preferred types, please state type and ident-no. when ordering

Type	Ident-No.	Type	Ident-No.
Please indicate in the ordering code the direction of rotation ("R" for clockwise rotation, "L" for counter-clockwise rotation)			
A2F5.6.0B7	9404452	A2FO90/61.-PAB05	9408467
A2FO10/61.-PAB06	9424894	A2FO90/61.-PBB05	9408472
A2FO10/61.-PBB06	9610682	A2FO107/61.-PAB05	9423259
A2FO12/61.-PAB06	9420472	A2FO107/61.-PBB05	9438282
A2FO12/61.-PBB06	9610683	A2FO125/61.-PAB05	9409641
A2FO16/61.-PAB06	9411113	A2FO125/61.-PBB05	9409642
A2FO16/61.-PBB06	9411121	A2FO160/61.-PAB05	9422192
A2FO23/61.-PAB05	9427223	A2FO160/61.-PBB05	9610688
A2FO23/61.-PBB05	9610684	A2FO180/61.-PAB05	9409371
A2FO28/61.-PAB05	9425164	A2FO180/61.-PBB05	9409358
A2FO28/61.-PBB05	9610685	A2FO200/63.-PAB05	2011993
A2FO32/61.-PAB05	9410193	A2FO250/60.-VPB05	915761
A2FO32/61.-PBB05	9410198	A2FO355/60.-VPH11	929470
A2FO45/61.-PZB05	9411585	A2FO500/60.-VPH11	932461
A2FO56/61.-PAB05	9425190	A2FLO710/60.-VPH11	962451
A2FO56/61.-PBB05	9610686	A2FLO1000/60.-VPH11	976184
A2FO63/61.-PAB05	9408527		
A2FO63/61.-PBB05	9408552		
A2FO80/61.-PAB05	9424687		
A2FO80/61.-PBB05	9610687		

Sizes 5...200: production plant Elchingen; Sizes 250...1000: production plant Horb

Fixed Displacement Pump A2FO