

**MANNESMANN
REXROTH**

Brueninghaus Hydromatik

**Scavenging and Pressure
Relief Valve Block SDVB**

Control Elements of the A4VSG and A2P

**RE
95533/03.96**

Replaces 01.82



The scavenging and pressure relief valve block serves to maintain the feed pressure, to exhaust excess oil and to limit the operating pressure in a closed hydraulic circuit.

Both service ports A and B can be pressurised with high or low pressure as required. The high pressure controlled scavenging spools ensure that upon changeover of the high and low pressure sides the scavenging valve is connected to the low pressure side.

Pilot operation of the double acting pressure relief valves allows simple setting, with minimum force, of the required pressure value for both pressure sides of the circuit. These settings may be carried out independent of one another. On sizes 30 and 50, remote control is also possible via external pilot oil connections (X and Y). When the relief valves are actuated, oil flows from the high pressure to the low pressure side.

The set pressure value corresponds to the pressure drop between high and low pressure side. This valve type is extremely compact in relation to its flow capacity.

The SDVB can also be used as a double-acting pressure relief valve. When used as a relief valve, the supply line to the scavenging valve is closed.

By means of independently or direct mounted unloading valves, the pilot valves can be connected externally with the tank or internally with the low pressure side. With this function the SDVB 30 and 50 can serve as a bypass valve. For high dynamic swivel operations with flushing and pressure relief valve block SDVB, when changing the high pressure side there will be free flow between A and B for a short time. Direct operated valve blocks are suitable for this application and are available in sizes 16 and 30 on request.

Scavenging and Pressure Relief Valve Block SDVB

Ordering code

SDVB				/				
------	--	--	--	---	--	--	--	--

Description

scavenging and pressure relief valve block piloted **SDVB**

Size

size 16	16
size 30	30
size 50	50

Model (see unit dimensions)

without direct operated flushing valve	without pre-load valve	N
with direct operated flushing valve	without pre-load valve	S
with direct operated flushing valve	without pre-load valve	T*
without direct operated flushing valve	with pre-load valve	V
with direct operated flushing valve	with pre-load valve	W
with direct operated flushing valve	with pre-load valve	Z*

* Model T and Z only for SDVB 16 (in prep.) and SDVB 30

Control type

pilot oil supply	pilot oil drain	unloading with/ without	
internal	internal	●	1
internal	external	●	2
external	internal	●	3
external	external	●	4
internal (de-energised when closed)	external	●	5¹⁾
internal with external pilot ports X-Y (plugged)	internal	●	6
internal (de-energised when open)	external	●	7¹⁾

¹⁾ both solenoids must be operated simultaneously

Model of port plate

port plate M 33	A
port plate M 42	B
port plate M 48	C
port plate SAE 1 1/2"	D
without port plate	N

Series

	20	30
--	-----------	-----------

SDVB 16
SDVB 30/50

Symbols for control type 5

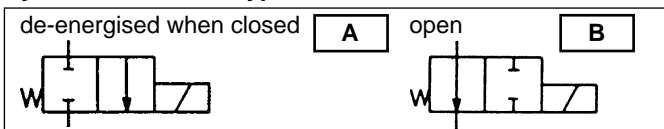

Voltages types for control type 5

12 V DC voltage - A closed	1
24 V DC voltage - B open	2
110-R AC voltage	3
220-R AC voltage	4
220-50 AC voltage	5

Scavenging and Pressure Relief Valve Block SDVB

Construction

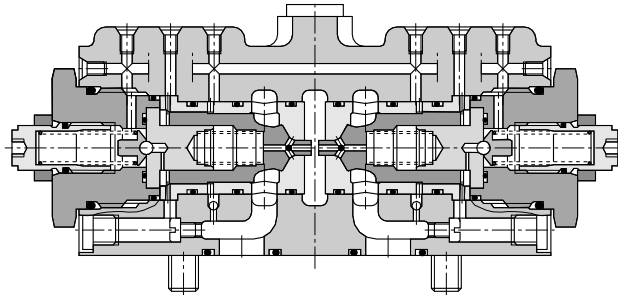

SDVB 16

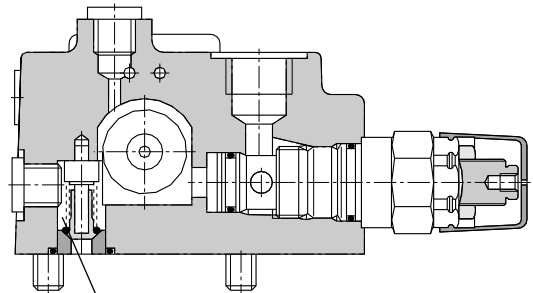

pre-load valve if A4VSG mounted

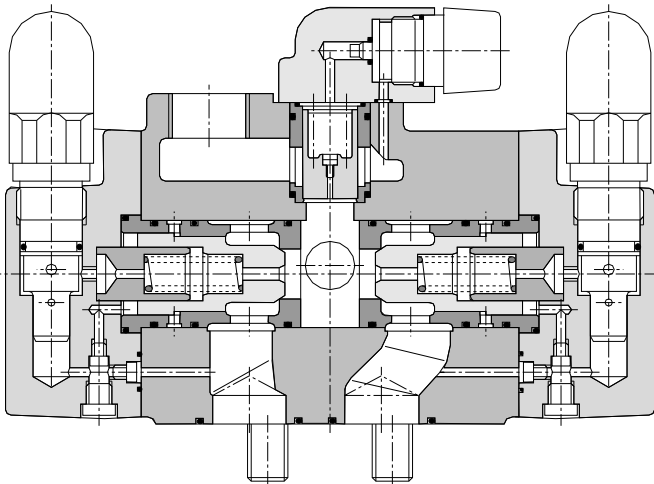

SDVB 30

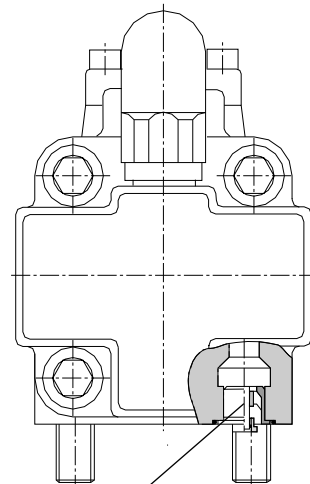

pre-load valve if A4VSG and A2P directly mounted

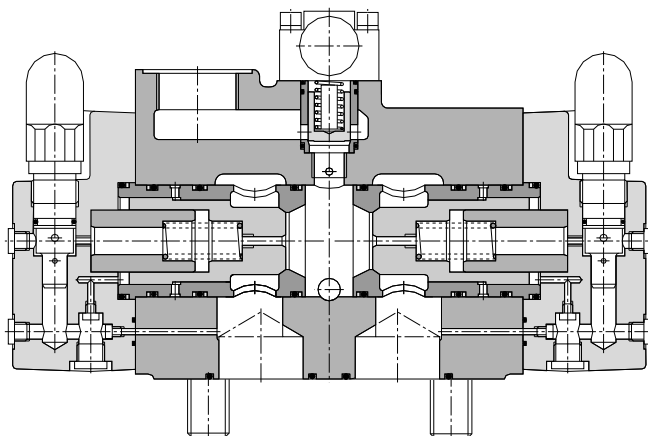

SDVB 50

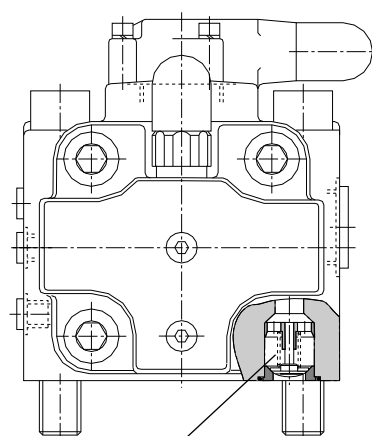

pre-load valve if A4VSG and A2P directly mounted

Control type (with pre-load valve)

Control Type 1

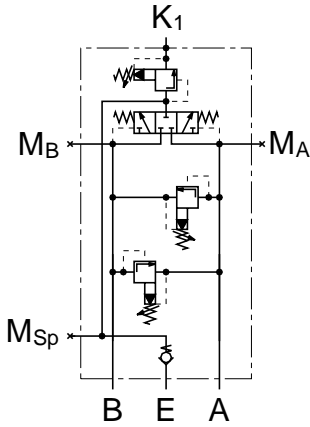

Control Type 2

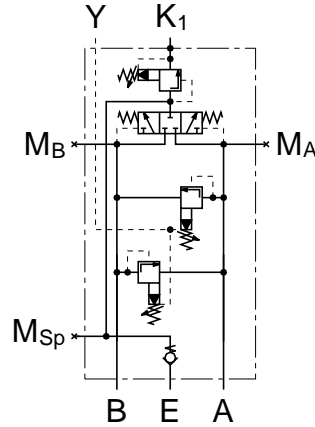

Control Type 3

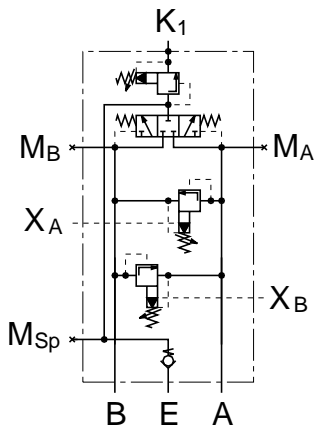

Control Type 4

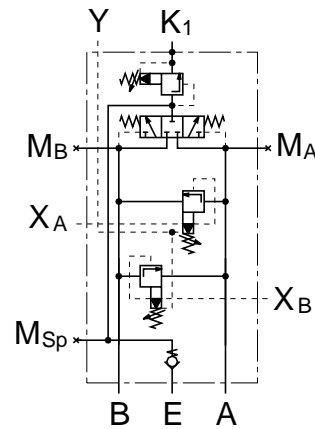

Control Type 5

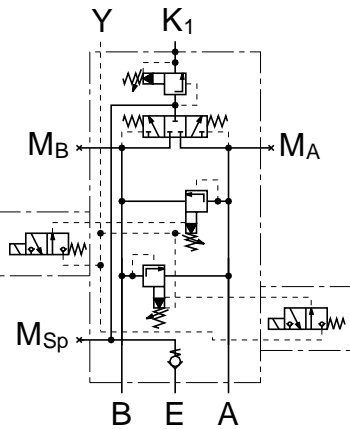

Control Type 6

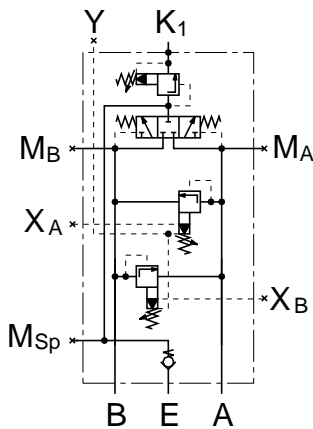

Control Type 7

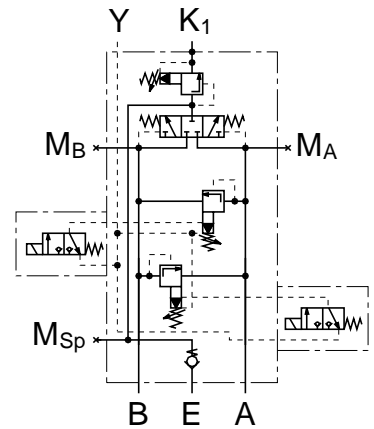

The types of control shown only apply to size 16.
 With the SDVB 30 and 50 there are two X and two Y ports.
 Control types for size 30 are same as those for sizes 16 and 50
 but without gauge ports MA and MB.

Scavenging and Pressure Relief Valve Block SDVB

Technical data (partly to VDI 3276)

Design: combined scavenging and pressure relief valves controlled by operating pressure

Mounting: flange model with O-ring seal (4 fixing holes in housing)

Pipe connections and connection sizes: see Unit Dimensions

Weight (kg)

Size	16	30	50
without subplate	6,5	23	61
with subplate		30	68

Mounting position: optional

Direction of flow: from A to B resp. B to A and from A to K_1 resp. B to K_1

Operating pressure range: $p_N = 0 \dots 400$ bar

The pressure measured at port $X_{A/B}$ is only identical to the pressure in the service line as long as the pressure relief valve is not actuated. Once the pilot valve has begun to open, the operating pressure in the main line can be around 15% higher. It is therefore recommended to measure the operating pressure direct at M_A or M_B resp. A or B.

Pressure setting range:

Operating pressure: $p_{v \min} \dots p_{v \max} = 50 \dots 400$ bar

Scavenging pressure at nominal flow Q_{NSp} : SDVB 16, 30 and 50 are infinitely adjustable. Please state the required pressure setting for operating pressure and scavenging pressure when ordering. More details see RE 92100.

Fluid temperature range

$\vartheta_{m \min} \dots \vartheta_{m \max} = -20^\circ \text{C} \dots +80^\circ \text{C}$

Viscosity range $v_{\min} \dots v_{\max} = 10 \dots 1000$ mm²/s

Nominal flow

Size	16	30	50
Main circuit Q_N (L/min)	200	600	1200
Scavenging circuit Q_{NSp} (L/min)	40	100	200

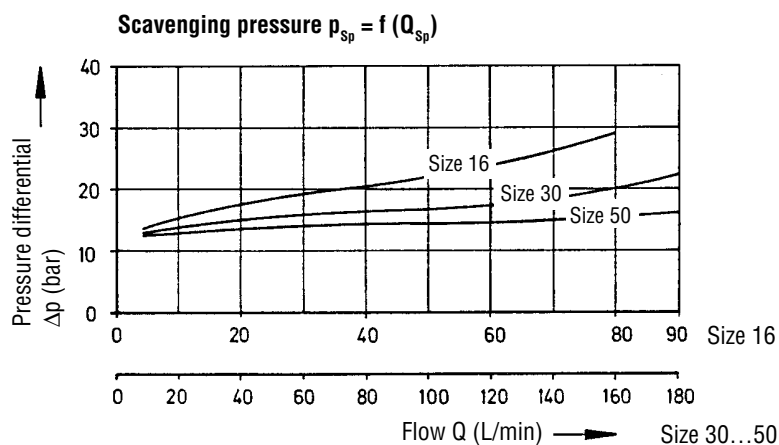
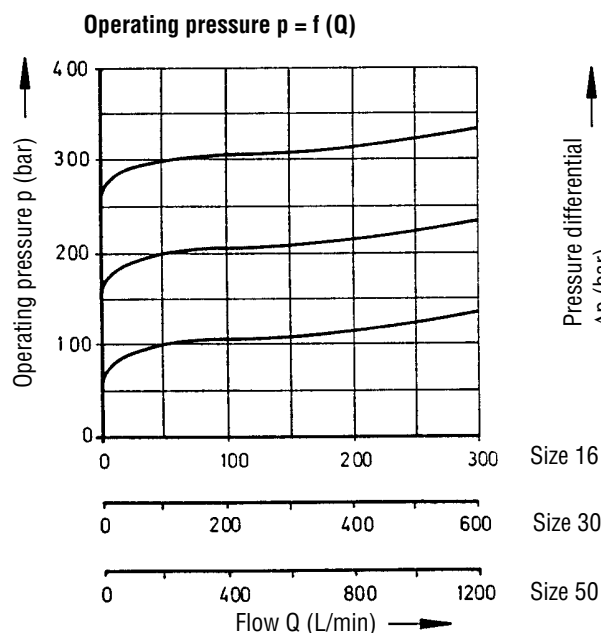
 Δp -Q-Characteristics**Pressure setting (Operating pressure)**

Size	16	30	50
p (bar/Umdr.) approx.	150	105	105

Scavenging and Pressure Relief Valve Block SDVB

SDVB 16

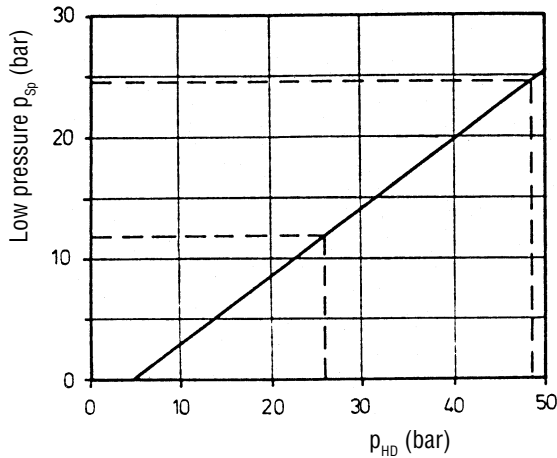

SDVB 30 and 50

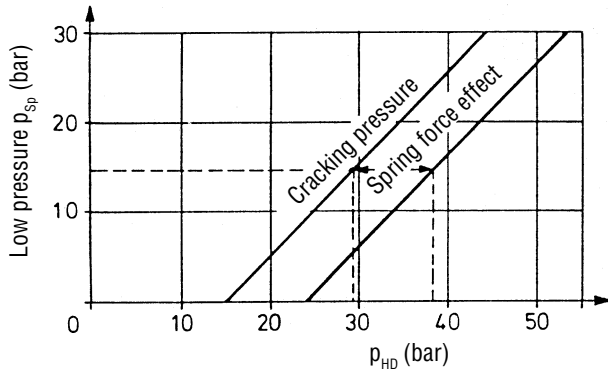

Co-ordination with axial piston units

Direct mounting

SDVB	Axial piston unit									
	A4VSG									
	40	71	125	180	250	355	500	750	1000	
16	●	●	●	●						
30					●	●	●			
50								●	●	

Switching pressure

In order to switch both sides of the circuit A and B to the scavenging valve, a pressure differential between the high pressure and low pressure sides is required.

This pressure differential and therefore the switching pressure on the high pressure side is dependent on the setting on the low pressure side. With the SDVB 30 and 50, the spring force effect must also be taken into consideration, since this requires a pressure increase of around 9 bar until the valve poppet is fully open (see diagrams on left).

Max. pilot oil volume

$Q_{St\ max}$ (taken from main circuit)			
Size	16	30	50
$Q_{St\ max}$ (L/min)	≈4	≈5	≈6

Remote control

To allow the setting of different pressure values for the pressure relief valves, external pilot oil connections "X" and "Y" are provided for remote control.

Functional variations

The SDVB 16 to 50 may also be used as a double acting pressure relief valve.

If only the double acting pressure relief valve function is required, the supply line to the scavenging valve is closed or the pressure setting of the scavenging valve is set higher than that on the relevant low pressure side.

A2P, Series 5				
	250	355	500	1000
	●	●	●	
				●

Unit Dimensions Size 16

Control Type 1

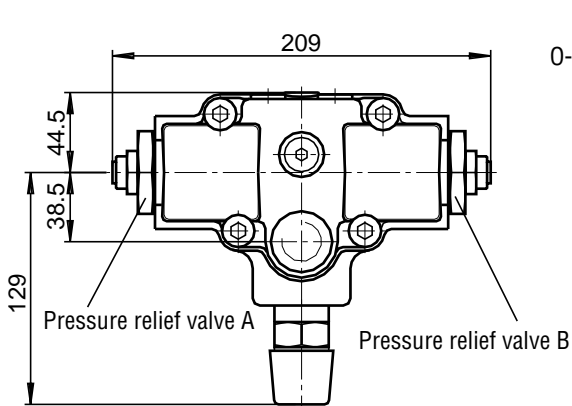

Control Type 2; 3; 4; 6

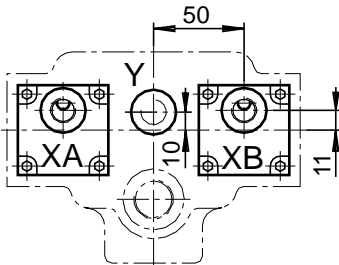

Control Type 5; 7

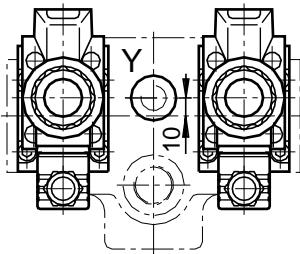

View Z

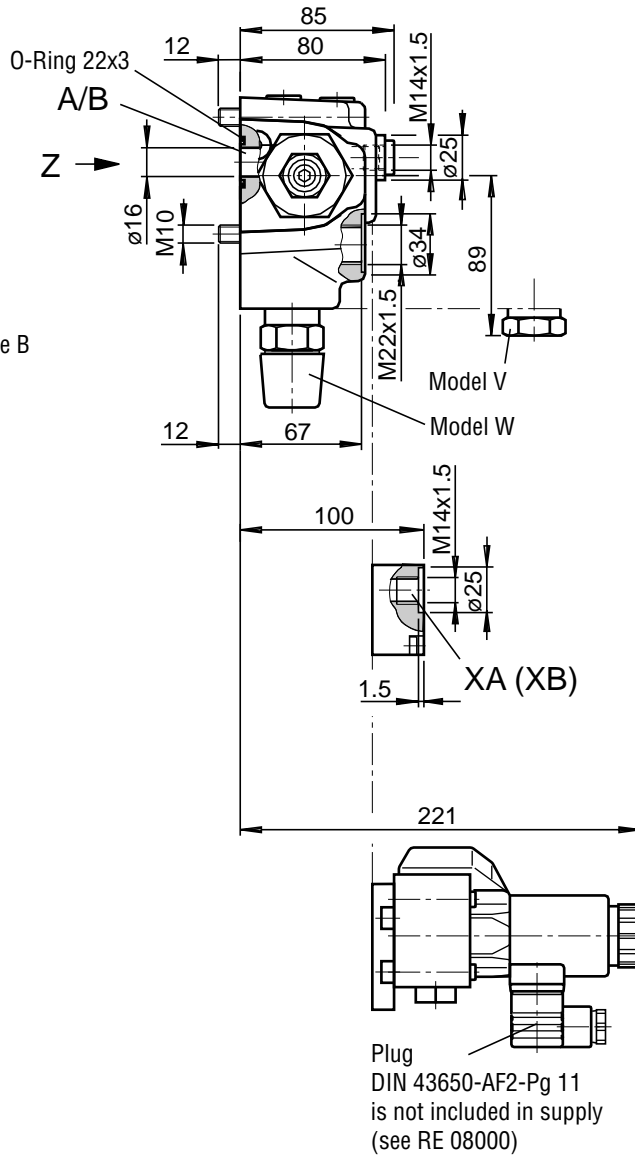
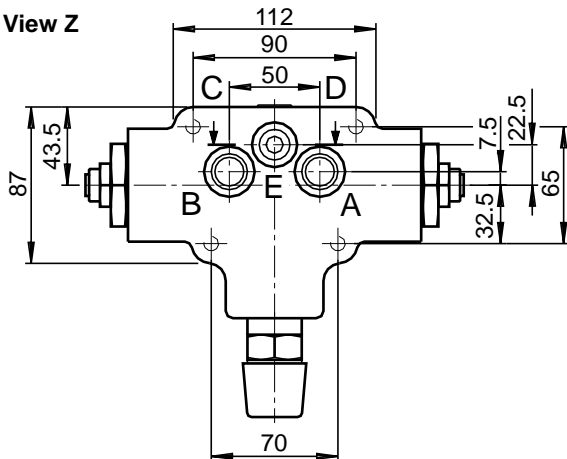

Section C-D

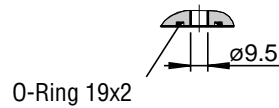

Unit Dimensions Size 50

Control Type 1

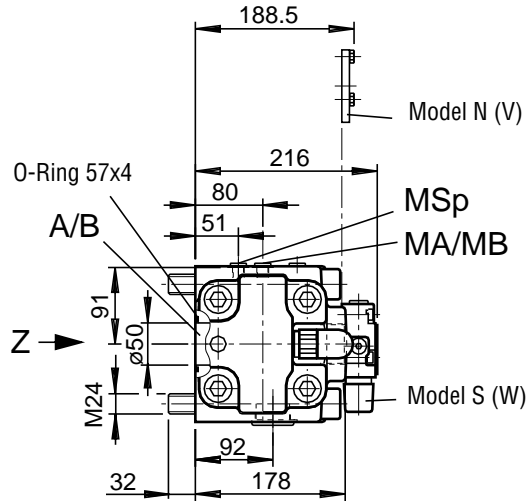
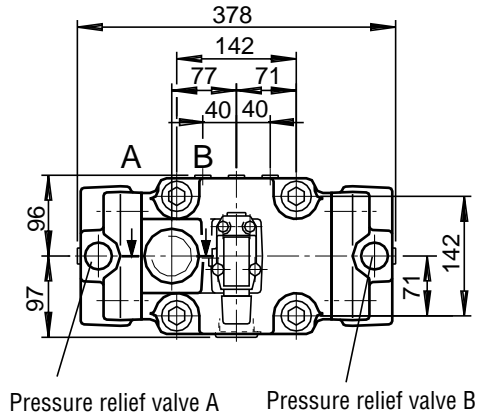

Control Type 2; 3; 4; 6

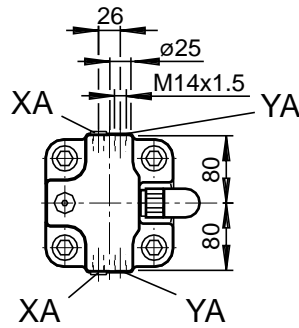
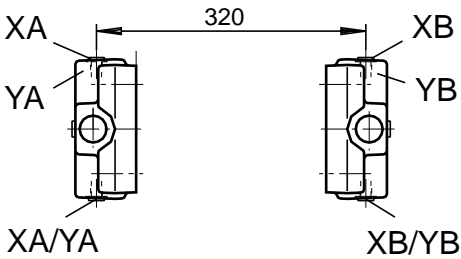

Control Type 5; 7

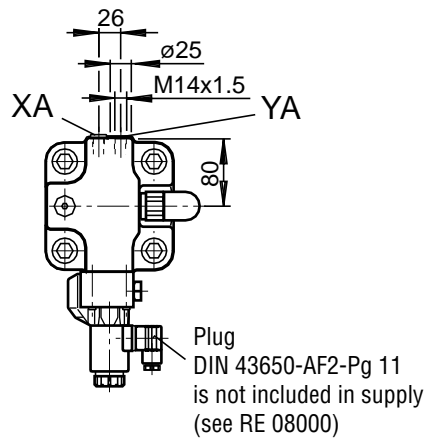
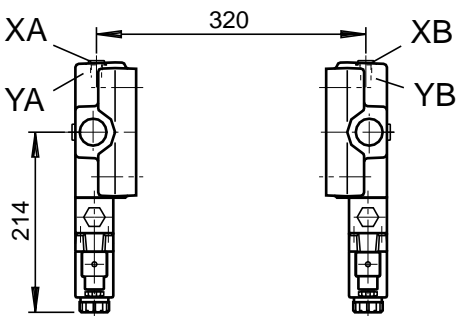

View Z

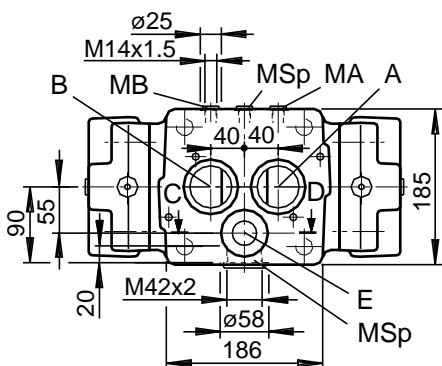

Section A-B

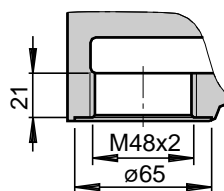

Section C-D

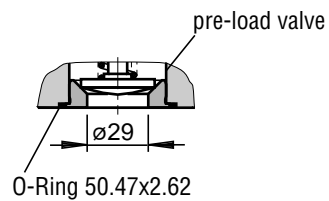

Subplate

SDVB 16 (M33x2)

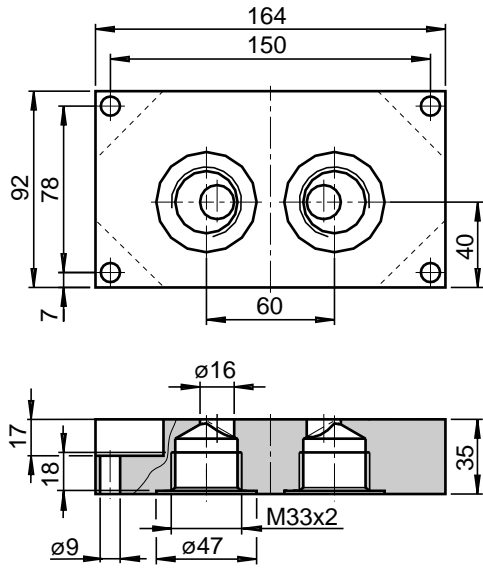

SDVB 16 (M42x2)

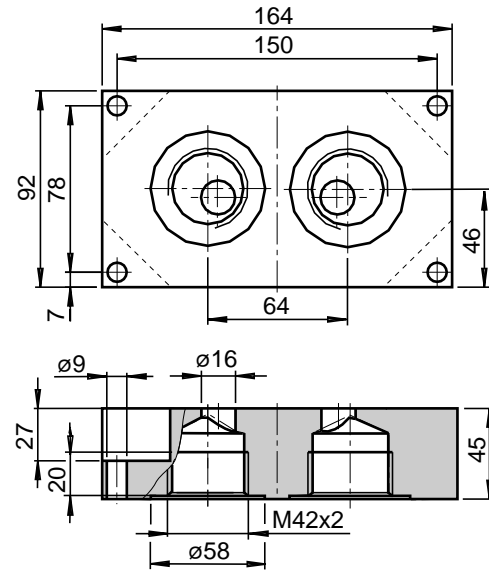

SDVB 30

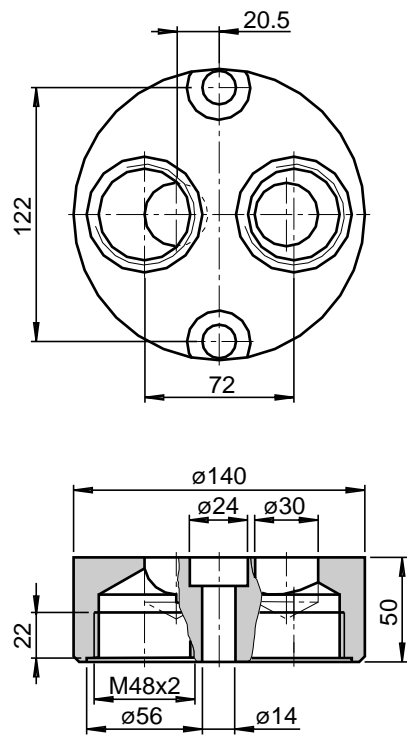

SDVB 50

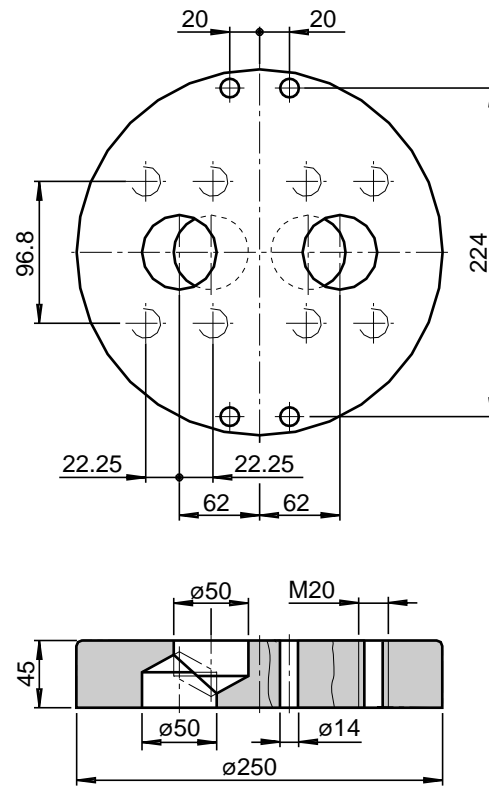

Unit Dimensions

A4VSG with scavenging block SDVB 16

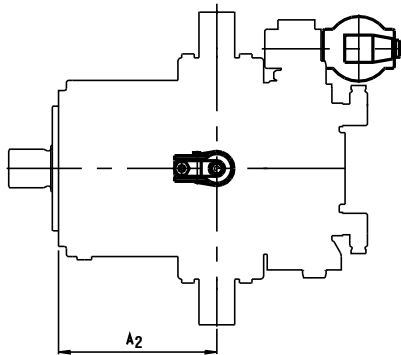
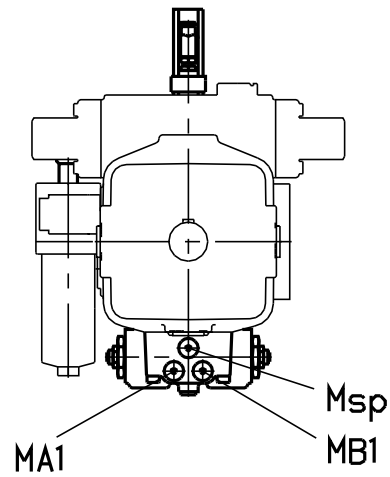
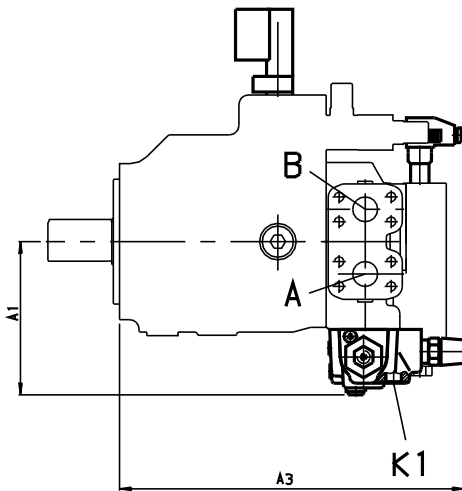
**Unit Dimensions**

Size	Unit Dimensions			Ports		
	A ₁	A ₂	A ₃	M _A , M _B	M _{SP}	K ₁
40	174	144	approx. 364	M14x1,5	M14x1,5	M22x1,5; 14 deep
71	177	166	389	M14x1,5	M14x1,5	M22x1,5; 14 deep
125	196,5	203	442	M14x1,5	M14x1,5	M22x1,5; 14 deep
180	196,5	203	442	M14x1,5	M14x1,5	M22x1,5; 14 deep
250	317	248	448	M14x1,5	M22x1,5	M33x2; 18 deep
355	319	248	455	M14x1,5	M22x1,5	M33x2; 18 deep
500	353	279	487	M14x1,5	M22x1,5	M33x2; 18 deep

Scavenging and Pressure Relief Valve Block SDVB